

# Material Lifts

## Load Lifter™

### Specifications

Model	Load Lifter	
Measurements	US	Metric
<b>A</b> Height - stowed	3 ft 9 in	1.14 m
Height - platform maximum	5 ft 7 in	1.70 m
<b>B</b> Length - stowed	1 ft 3 in	.38 m
Length - operating	2 ft 8 in	.81 m
<b>C</b> Width - stowed	1 ft 8.5 in	.52 m

### Productivity

Load capacity	200 lbs	91 kg
<b>D</b> Load height minimum	2 in	.05 m
Ground clearance - center	.75 in	.02 m
<b>E</b> Load platform length	1 ft 2 in	.36 m
<b>F</b> Load platform width	1 ft 4.75 in	.43 m

### Power

Average cranks - per length unit		
Standard winch - carriage moving	4.8/ft	15.6/m
Standard winch - mast moving	2.0/ft	5.6/m

### Weight\*

	58 lbs	26 kg
--	--------	-------

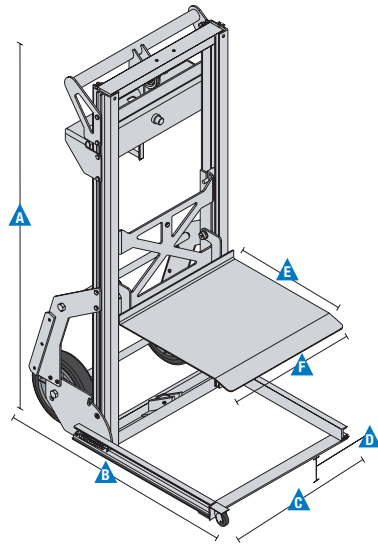

\* Weight will vary depending on options and/or country standards.

### Features

#### Standard Features

##### Measurements

- 5 ft 7 in (1.70 m) lifting height
- Up to 200 lbs (91 kg) load capacity

##### Productivity

- Portable and compact design
- Lightweight aluminum construction for easy transport
- High strength aircraft quality cable
- Cushioned neoprene hand grip
- Beveled aluminum platform for easy loading and unloading
- Portable - folds for compact storage
- 8 in solid (20 cm) non-marking rear wheels
- Stair glides for easy handling on stairs
- Hold-down mechanism secures for transport

##### Power

- Quiet high-speed winch
- Reversible winch handle for easy storage

#### Options & Accessories

##### Base

- Industrial base – includes steel winch mount, GL™ winch, foot brake and front swivel casters

##### Wheel / Caster Options

- Pneumatic 8 in (20 cm) rear wheels for rough terrain (not available with Industrial Base)
- 2 in (5 cm) non-marking front swivel casters
- Foot brake



#### Genie United States

6464 185th Ave. NE  
Redmond, WA 98052  
Telephone +1 (425) 881-1800  
Toll Free in USA/Canada +1 (800)-536-1800  
Fax +1 (425) 883-3475

#### Distributed By:

Effective Date: January, 2016. Product specifications and prices are subject to change without notice or obligation. The photographs and/or drawings in this document are for illustrative purposes only. Refer to the appropriate Operator's Manual for instructions on the proper use of this equipment. Failure to follow the appropriate Operator's Manual when using our equipment or to otherwise act irresponsibly may result in serious injury or death. The only warranty applicable to our equipment is the standard written warranty applicable to the particular product and sale and we make no other warranty, express or implied. Products and services listed may be trademarks, service marks or trade names of Terex Corporation and/or their subsidiaries in the USA and many other countries. Terex, Genie and AWP are registered trademarks of Terex Corporation or its subsidiaries. © 2016 Terex Corporation.